

# DFKM-PB Ball Joint (Male Screw) - Round Pipe Mounting NEW

WEB Selection Tool   
 WEB CAD Download   
 Pipe

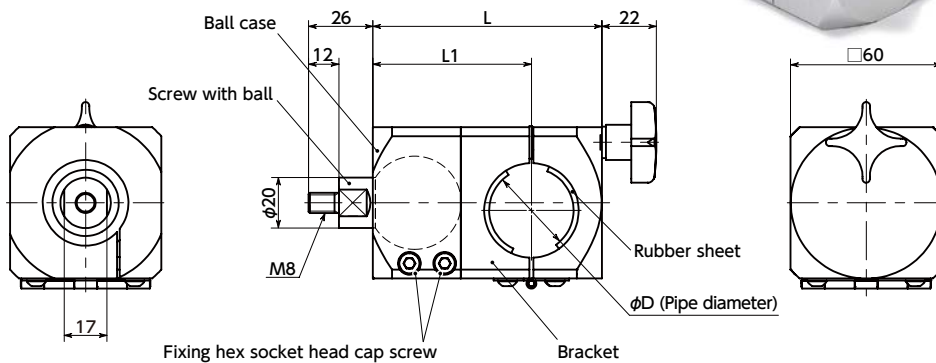

## ● Material/Finish

RoHS2 Compliant

	<b>DFKM-PB</b>
Ball Case	A6063 Anodized
Screw with ball	S45C Trivalent Chromate Treatment
Fixing Hex Socket Head Cap Screw (M5×16mm)	SCM435 Ferrosulfuric Oxide Film
Bracket	A6063 Anodized
Rubber sheet	NR (Natural Rubber)

- A positioning component utilizing a ball screw. Mount the workpiece to the screw at the ball tip for use.
- The screw with ball can be tilted by  $\pm 15^\circ$  and rotated in any direction within  $360^\circ$ .
- By tightening the fixing hex socket head cap screw, securely retain the angle after adjustment.
- Can be mounted to round pipe.

## ● Application

Machine tool / Medical equipment / FPD production device / Semiconductor manufacturing device / Packing machine / Food machinery

Unit : mm

Part Number <span style="color: red;">1</span>	D	L	L <sub>1</sub>	Tightening Torque *1 (N·m)	Fixing Hex Socket Head Cap Screw Tightening Torque Reference Value (N·m)	Screw With Ball Retention Torque *2 (N·m)	Max. Load Weight (kg)	Mass (g)
<b>DFKM-60-M8-PB-28</b>	28	83	59	12.5	3	10	10	810
<b>DFKM-60-M8-PB-30</b>	30	83	59	12.5	3	10	10	810
<b>DFKM-60-M8-PB-34</b>	34	83	59	12.5	3	10	10	770
<b>DFKM-60-M8-PB-40</b>	40	91	63	12.5	3	10	10	790
<b>DFKM-60-M8-PB-42.7</b>	42.7	91	63	12.5	3	10	10	760

\*1 : Screw tightening torque of the screw with ball.

\*2 : Retention torque is the value indicated when the hex socket head cap screw is tightening to the torque indicated.

● Fixing rubber sheet is attached. Dimensional allowance of available round pipe is  $\pm 0.5$  mm.

## ● Related Products

Female screw type **DFKF-PB**  
**DFKWF-PB** with the same shape as **DFKM-PB** is available.  
**DFKF-PB** → P.xxxx  
**DFKWF-PB** → P.xxxx



**DFKM-AF** for mounting to aluminum frame/wall panel/sheet metal and **DFKM-AA** for mounting to aluminum frame end surfaces are available.

**DFKM-AF** → P.xxxx  
**DFKM-AA** → P.xxxx



- Part number specification

**DFKM-60-M8-PB-30**

1