

# MOM Flexible Couplings - Oldham Type Registered Design

High torque High Rigidity

## Structure

### Set Screw Type

**MOM** → P.xxxx

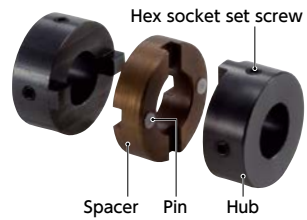

### Clamping Type

**MOM-C** → P.xxxx



### Set Screws + Key Type

**MOM-K** → P.xxxx



### Clamping + Key Type

**MOM-CK** → P.xxxx



### Material/Finish



	MOM / MOM-C / MOM-K / MOM-CK
Hub	S45C Ferrosoferric Oxide Film (Black)*1
Spacer	FCD400 Ferrosoferric Oxide Film (Black)
Pin	Polyacetal
Hex Socket Set Screw	SCM435 Ferrosoferric Oxide Film (Black)
Hex Socket Head Cap Screw	SCM435 Ferrosoferric Oxide Film (Black)
Grease	Lithium Soap Grease Nippeco DXL-No.1 Made by Nippeco

\*1: Due to manufacturing process requirements, couplings may have bores and keyways with or without surface treatment. This does not affect the performance of the couplings.

### Applicable motors

	MOM
Servomotor	●
Stepping Motor	●
General-purpose Motor	○

○: Excellent ●: Available

### Property

	MOM
High Torque	○
High Torsional Stiffness	○
Allowable Misalignment	○

○: Excellent ○: Very good

- This is an oldham type flexible coupling.
- FCD400 is adopted in the spacer. Suitable for low-speed and high-torque specification.
- High performance grease is applied in the gap between hubs and the spacer in order to prevent sticking.
- Slippage of hubs and a spacer allows large eccentricity and angular misalignment to be accepted.
- A projection placed in the spacer (resin pin) allows angular misalignment to be effortlessly accepted.
- The grease accumulated in a grease hole will gradually seep out during operation, thereby maintaining the lubrication property over a long period.



### Application

Mixer / Pump / Small power press / Grinder

### ⚠️ Precautions for Use

Please apply grease periodically in order to prevent sticking of hubs and a spacer.

### Part number specification

**MOM-30K-12-14**

Product Code Size Bore Diameter

Please refer to dimensional table for part number specification.

### Spacer's projection structure

Spacer's projection structure allows large angular to be effortlessly accepted. It reduces burden on the shaft.

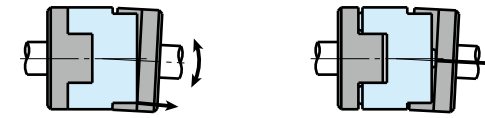

(Without projection)

(With projection)

In the oldham-type coupling whose spacer has no projection, the spacer and hubs interfere with each other near outside diameter, so that the max. angular misalignment is small and that the bending moment arises on the shaft.

NBK's oldham type coupling allows the angular misalignment to be easily accepted since the projection serves as support. Bending moment does not arise. Therefore, the max. angular misalignment is large and the burden on the shaft is reduced. **MOM** is provided with a projection by inserting a resin pin into the spacer.

## Selection

### Selection Based on Shaft Diameter and Rated Torque

The area bounded by the shaft diameter and rated torque indicates the selection size.

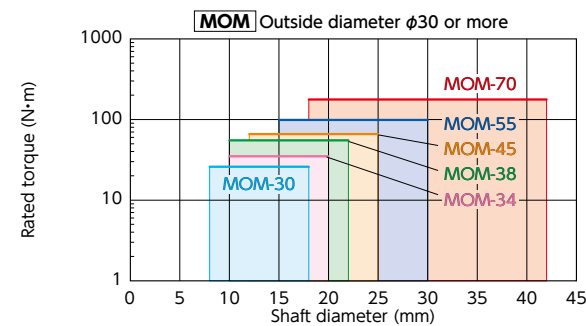
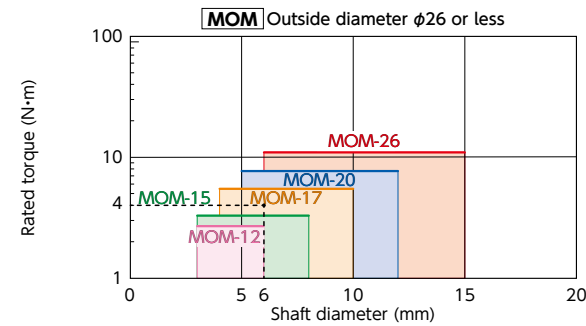

### Selection Example

In case of selected parameters of shaft diameter of φ 6 and load torque of 4N·m, the selected size is

**MOM-17**.



Additional Keyway at Shaft Hole → P.xxxx    Cleanroom Wash & Packaging → P.xxxx    Change to Stainless Steel Screw → P.xxxx  
Available / Add'l charge    Not Available    Not Available

# MOM-C Flexible Couplings - Oldham Type - Clamping Type Registered Design

High torque High Rigidity

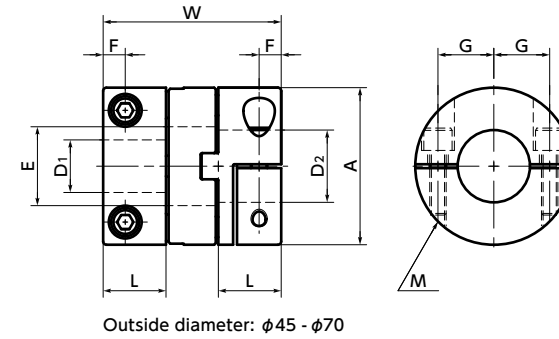
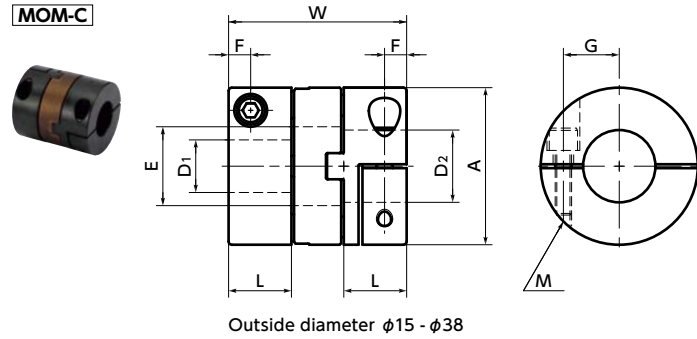

## Dimensions

Unit : mm

Part Number	A	L	W	E	F	G	M	Screw Tightening Torque (N·m)
MOM-15C	15	6.6	19	6.9	2.15	5.2	M1.6	0.25
MOM-17C	17	9	25	7.3	2.65	5.5	M2	0.5
MOM-20C	20	10	28	11.1	3.25	7.25	M2.5	1
MOM-26C	26	11.5	31.6	13.3	4	9	M3	1.5
MOM-30C	30	12	34	15.5	4	11	M3	1.5
MOM-34C	34	13	35	17.5	4.5	12	M4	3.5
MOM-38C	38	15	40.5	21.5	4.75	14	M4	3.5
MOM-45C	45	16.2	47.6	24.3	6.2	16	M5	8
MOM-55C	55	20.8	58.6	27.7	7.9	20	M6	13
MOM-70C	70	25	68.6	38.5	8.9	26	M6	13

Part Number	Standard Bore Diameter D1/D2																			
	3	4	5	6	6.35	8	10	12	14	15	16	18	20	22	24	25	28	30	35	
MOM-15C	●	●	●	●																
MOM-17C		●	●	●																
MOM-20C			●	●	●	●	●													
MOM-26C				●	●	●	●	●												
MOM-30C					●	●	●	●	●											
MOM-34C						●	●	●	●	●										
MOM-38C							●	●	●	●	●									
MOM-45C								●	●	●	●	●								
MOM-55C									●	●	●	●	●	●	●	●				
MOM-70C										●	●	●	●	●	●	●	●	●	●	●

- All products are provided with hex socket head cap screw.
- Recommended tolerance for shaft diameters is h6 and h7.
- A set of hubs with set screw type for one side and clamping type or other type for the other side is available upon request.
- For the shaft insertion amount to the coupling, see Mounting/maintenance.

### ⚠ Precautions for Use

- In case of mounting on D-cut shaft, be careful about the position of the D-cut surface of the shaft. → P.xxxx
- There are sizes where the hex socket head bolt exceeds the outer diameter of the coupling and the rotating diameter is larger than the outer diameter. Please be careful of the interference of coupling. → P.xxxx

Additional Keyway at Shaft Hole → P.xxxx	Cleanroom Wash & Packaging → P.xxxx	Change to Stainless Steel Screw → P.xxxx
Available / Add'l charge	Not Available	Not Available

## Performance

Part Number	Max. Bore Diameter (mm)	Keyway Additional Modification Max. Bore Diameter (mm)	Rated Torque *1 (N·m)	Maximum Torque *1 (N·m)	Max. Rotational Frequency (min <sup>-1</sup> )	Moment *2 of Inertia (kg·m <sup>2</sup> )	Static Torsional Stiffness (N·m/rad)	Max. Lateral Misalignment *3 (mm)	Max. Angular Misalignment (°)	Mass *2 (g)
MOM-15C	6	6	3.3	6.6	2000	6.2×10 <sup>-7</sup>	870	0.3	2	19
MOM-17C	6.35	6	5.5	11	2000	1.4×10 <sup>-6</sup>	1300	0.3	2	34
MOM-20C	10	10	7.7	15.4	2000	3.0×10 <sup>-6</sup>	1700	0.4	2	47
MOM-26C	12	12	11	22	2000	9.6×10 <sup>-6</sup>	3200	0.5	2	92
MOM-30C	14	14	26	52	2000	1.8×10 <sup>-5</sup>	4600	0.6	2	131
MOM-34C	16	16	35	70	2000	3.1×10 <sup>-5</sup>	6000	0.7	2	173
MOM-38C	20	20	55	110	2000	5.5×10 <sup>-5</sup>	7400	0.8	2	235
MOM-45C	22	22	66	132	2000	1.2×10 <sup>-4</sup>	16000	1	2	387
MOM-55C	25	25	99	198	2000	3.4×10 <sup>-4</sup>	30000	1.2	2	752
MOM-70C	35	35	176	352	2000	1.0×10 <sup>-3</sup>	46000	1.4	2	1370

\*1 : Values with no load fluctuation and rotation in a single direction. If there is large load fluctuation, or both normal and reverse rotation, select a size with some margin.

※ The shaft's slip torque may be smaller than the coupling's rated torque depending on the shaft bore. → P.xxxx

\*2 : These are values with max. bore diameter.

\*3 : The max. lateral misalignment varies depending on the load torque and revolution. → P.xxxx

### • Comparison of rated torque

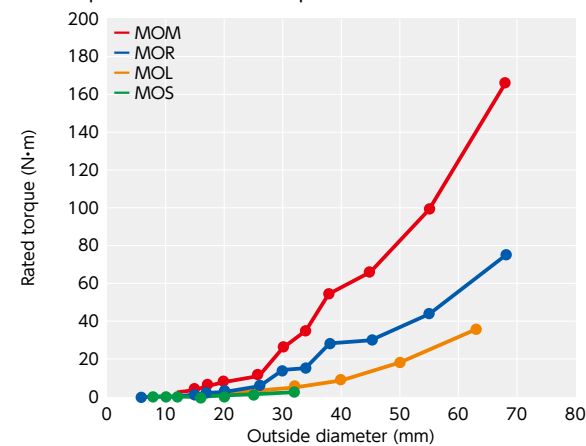

### • Comparison of Static Torsional Stiffness

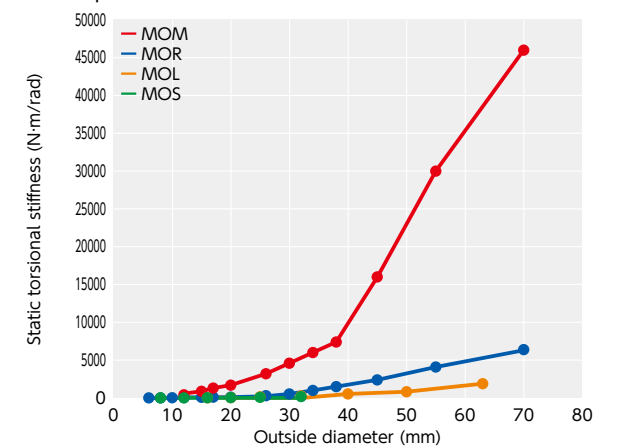

### • Part number specification

**MOM-55C-15-16**

### Technical Information

● Max. Lateral Misalignment

MOM's max. lateral misalignment varies depending on the load torque and revolution.

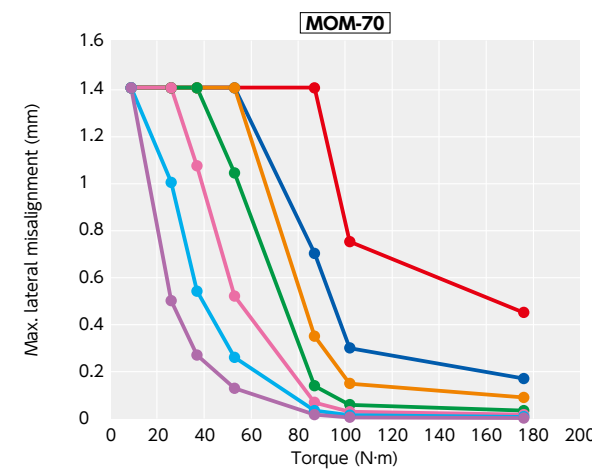
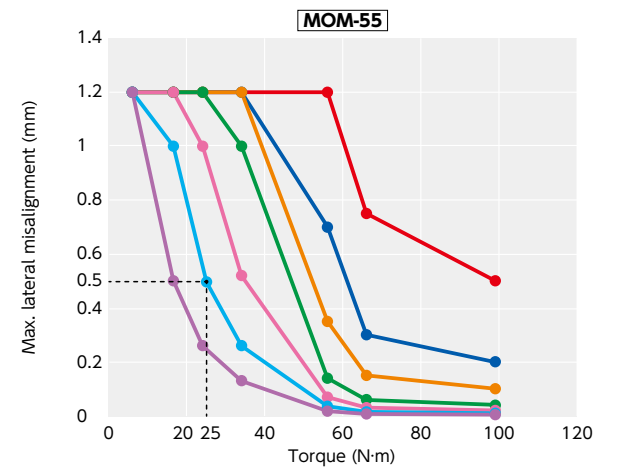
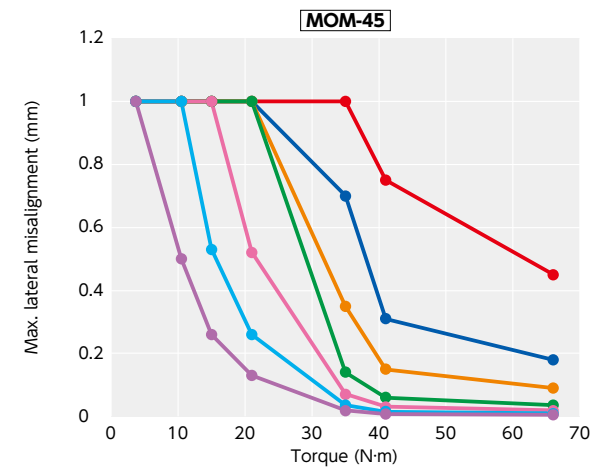
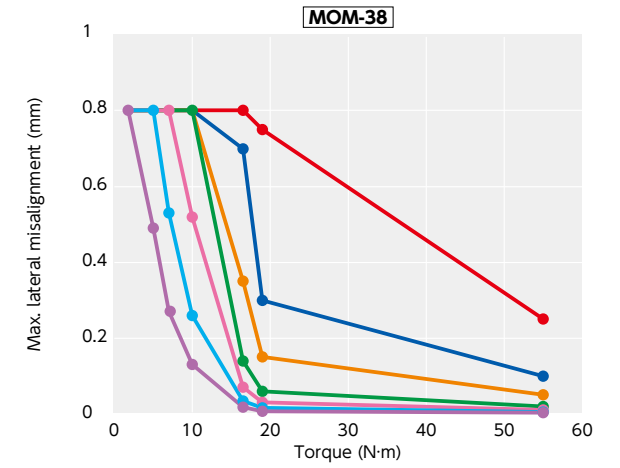
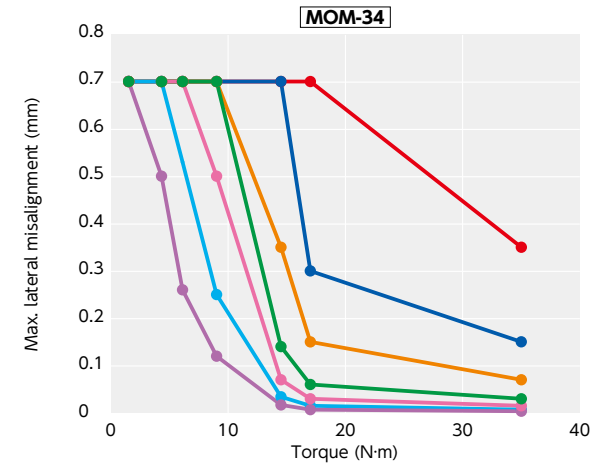
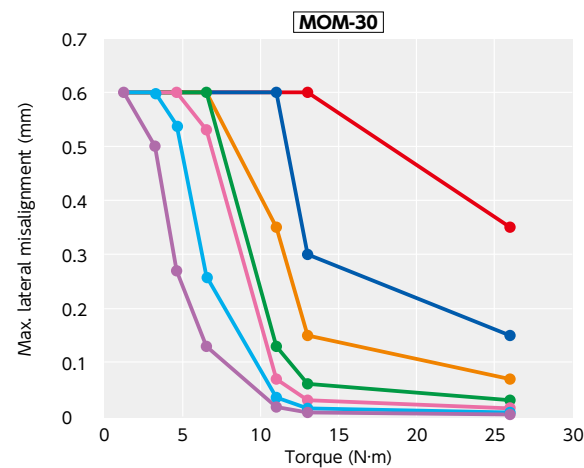
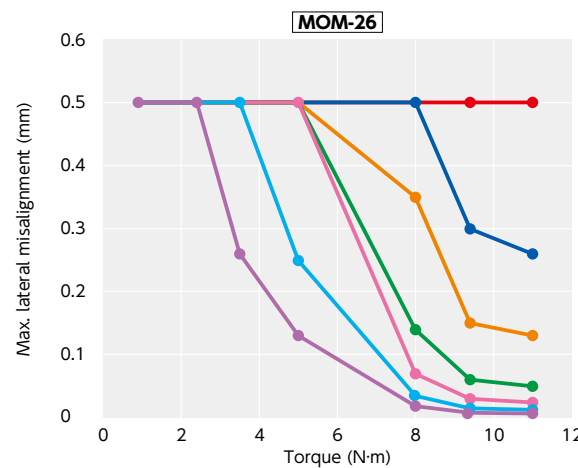
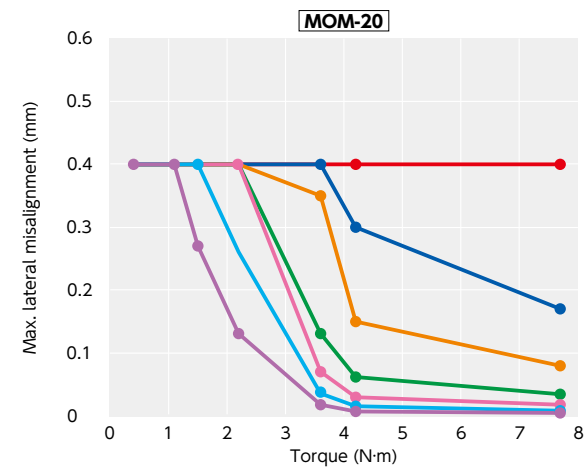
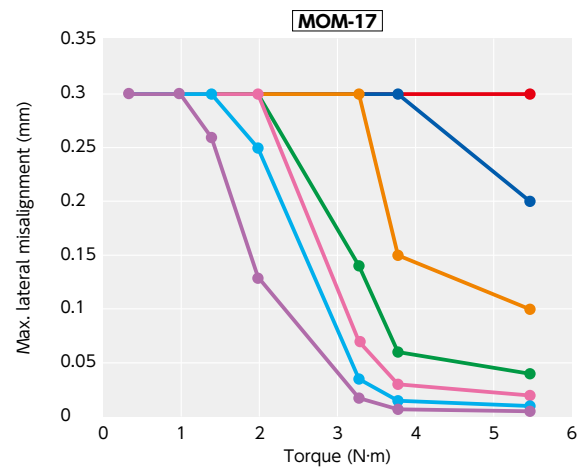
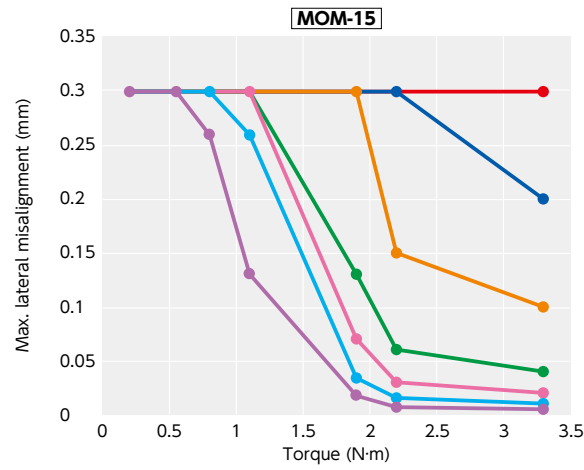
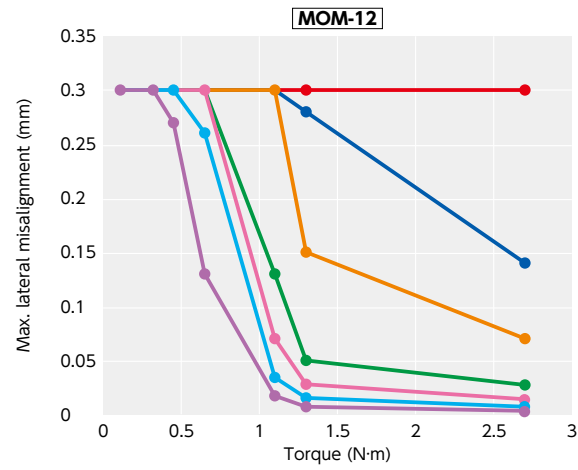

● Example  
When load torque is 25 N•m and revolution is 1000 min<sup>-1</sup>, the max. lateral misalignment of **MOM-55** is 0.5 mm.



● Change in static torsional stiffness due to temperature

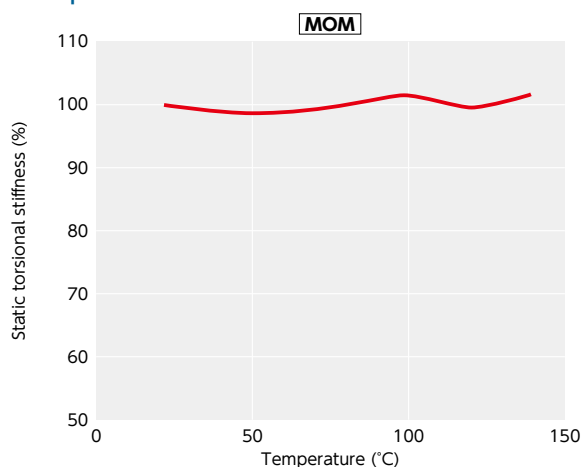

This is a value under the condition where the static torsional stiffness at 20°C is 100%. The change of **MOM** in torsional stiffness due to temperature is small and the change in responsiveness is extremely small.

If the unit is used under higher temperature, be careful about misalignment due to elongation or deflection of the shaft associated with thermal expansion.

● Slip Torque

For set screw type **MOM**, see Carbon Steel Coupling under "Slip Torque of Coupling - Set Screw Type" for details.

As in the table below, the clamping type **MOM-C** has different slip torque according to the bore diameter. Take care during selection.

Unit : N · m

Part Number	Bore Diameter																			
	3	4	5	6	6.35	8	10	12	14	15	16	18	20	22	24	25	28	30	35	
<b>MOM-15C</b>	0.3	0.5	0.8	1																
<b>MOM-17C</b>		2.1	3.5	3.7																
<b>MOM-20C</b>			3.8	6	6	6.8	7.5													
<b>MOM-26C</b>				5.4	5.4	5.8	6.6	8.7												
<b>MOM-30C</b>						7.4	12	14	15											
<b>MOM-34C</b>							13	13	15	16	16									
<b>MOM-38C</b>							16	18	20	23	25	28	31							
<b>MOM-45C</b>								47	48	56	56	57	62							
<b>MOM-55C</b>										42	54	55	56	89	93	97				
<b>MOM-70C</b>													62	92	95	97	100	110	120	130

- These are test values based on the conditions of shaft dimensional allowance: h7, hardness: 34 - 40 HRC, and screw tightening torque of the values described in **MOM-C** dimension tables. They are not guaranteed values.
- Slip torque changes with usage conditions. Carry out tests under conditions similar to actual conditions in advance.